



# JLG Series GEL battery JLG12-200

## General Features

- ▶ Nanosilica colloidal electrolyte and high tin positive plate alloy design to enhance battery performance
- ▶ Relatively rich electrolyte, high temperature and low temperature performance is superior
- ▶ Long cycle life, excellent deep cycle discharge ability
- ▶ Excellent charge acceptance ability
- ▶ Precision sealing technology



**Dimension: 522(L) × 240(W) × 219(H) × 222(TH)**

**Unit: mm**

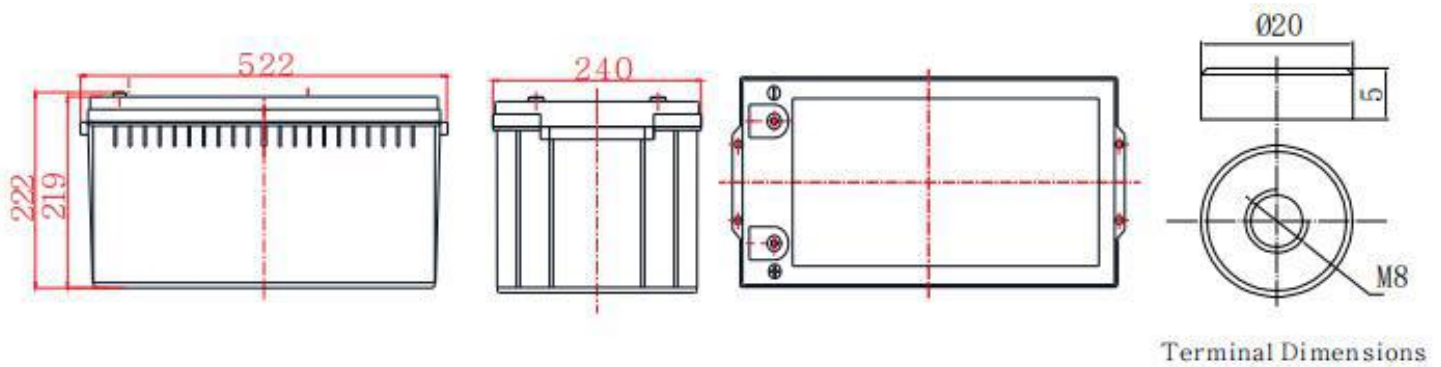

Specification	
Nominal Voltage	12V
Nominal Capacity	200Ah
Design life	10 years
Terminal	M8
Approx. Weight	Approx 61.8kg (136.2lbs)
Container Material	ABS
short-circuit current	3000A
Internal resistance(Full charged at 25°C: )	4.0 mΩ
Self discharge	3% of capacity declined per month at 25°C
Operating Temperature	
Discharge:	-40 ~60°C(-40~ 140°F)
Charge :	-20 ~50°C(-4~ 122°F)
Storage:	-20 ~50°C(-4~ 122°F)
Charge Method(25 °C)	
Charge current:	Max. 50.0A; Recom.20.0A
Float charge:13.5-13.8V	recom.13.8V(-18mV/ °C)
Equalize charge:13.8-14.1V	recom.14.1V(-24mV/ °C)
Cycle charge:14.4-15.0V	recom.14.7V(-30mV/ °C)

## Applications

- ▶ UPS/EPS
- ▶ Power systems
- ▶ Telecommunications system
- ▶ Emergency lighting, Auto control system
- ▶ Solar / wind energy and other new energy storage
- ▶ Other general purpose

## Rated Capacity

20Hour Rate (10.0A to 10.5V)	200.0Ah
3Hour Rate (53.2A to 10.2V)	159.6Ah
1Hour Rate (123A to 9.6V)	123.0Ah

## Attain Certificate



Disclaimer: Manufacturers have the right to self-modify the parameters of the product updates, please keep in touch with manufacturers to obtain the latest information.

## Discharge characteristic

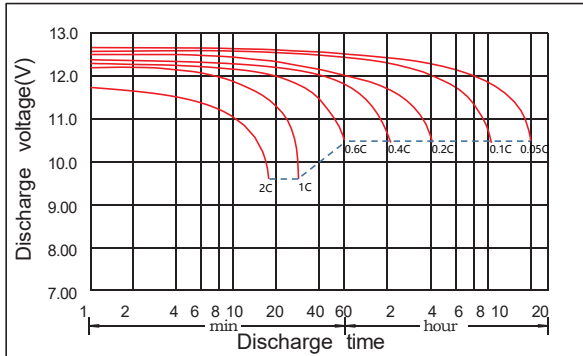

## Charging characteristic

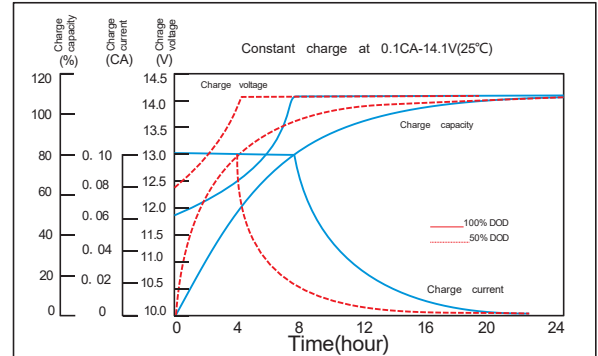

## The effect of temperature on capacity

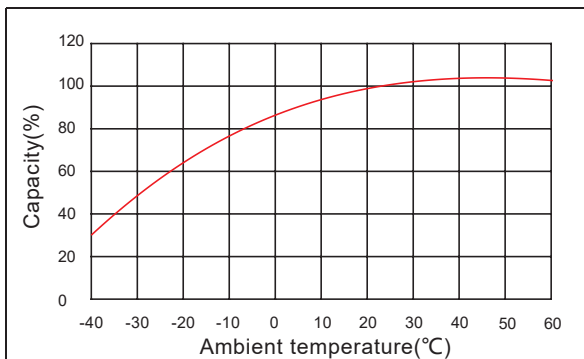

## Curves of open circuit voltage vs. capacity

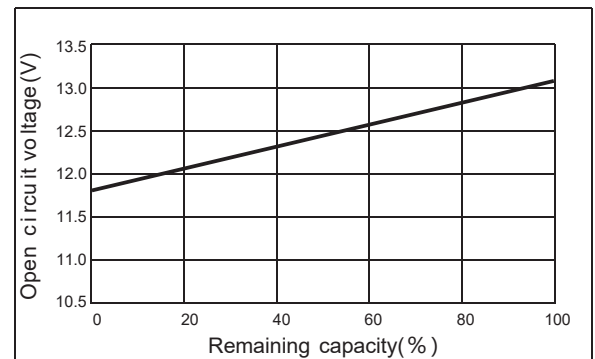

## Constant Current Discharge Characteristics Unit:A (25°C,77°F)

FV/Time	5min	10min	15min	30min	45min	1h	1.5h	2h	3h	4h	5h	6h	8h	10h	20h
1.60V	306	306	306	200	155	123	82.9	76.1	54.6	39.6	36.7	29.3	24.1	20.3	10.4
1.65V	301	301	301	197	153	122	82.0	75.1	54.1	39.2	36.4	29.0	23.9	20.1	10.3
1.70V	289	289	289	193	151	121	81.0	74.1	53.2	38.8	36.0	28.7	23.7	19.9	10.1
1.75V	266	266	266	192	150	120	80.5	73.2	52.7	38.5	35.6	28.5	23.5	19.8	10.0
1.80V	238	238	238	183	144	117	79.5	71.7	52.2	38.1	34.6	28.1	23.3	19.5	9.85
1.85V	212	212	212	167	133	108	77.1	68.3	49.3	37.0	32.9	27.3	22.4	19.0	9.61

## Constant Power Discharge Characteristics Unit: W/cell (25°C ,77°F )

FV/Time	5min	10min	15min	30min	45min	1h	1.5h	2h	3h	4h	5h	6h	8h	10h	20h
1.60V	520	520	520	360	287	235	161	148	106	76.7	71.2	57.1	46.9	39.6	20.5
1.65V	512	512	512	354	283	234	159	146	105	76.0	70.6	56.6	46.6	39.3	20.2
1.70V	491	491	491	348	280	232	157	144	103	75.2	69.8	55.7	46.3	38.8	19.9
1.75V	452	452	452	345	278	229	156	142	102	74.6	69.0	55.3	46.0	38.5	19.6
1.80V	404	404	404	330	267	223	154	139	101	73.9	67.1	54.5	45.5	38.0	19.3
1.85V	363	363	363	303	247	208	150	133	96.1	72.1	64.1	53.3	43.9	37.2	18.9